

AquaLynx[®]
Model 250 RO-AC-ENC-V2
RO Controller

**Installation and
Operating Manual**

505-334-5865 ph 505-334-5867 fax
www.rodissystems.com
email: info@rodissystems.com
936 Highway 516 Aztec, NM 87410

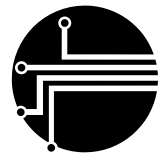

RODI
systems

Manual Revisions

i

AquaLynx® Model 250 RO-AC-ENC-V2 Monitoring and Control System

Installation and Operating Manual

Copyright 2020 RODI Systems Corp.

NOTICE

This manual is protected by federal copyright laws. It should not be copied in any way, shape, or fashion without the written permission from RODI Systems Corp.

Version 1.40

For product and service information:

RODI Systems Corp.
936 Hwy 516
Aztec, NM 87410
Telephone: 505-334-5865
Fax: 505-334-5867
Email: info@rodisystems.com

Version History

Version	Date	Effective Pages	Description of Changes
1.00	02/12/18	-	Preliminary Issue
1.10	04/27/18	-	Initial Release
1.20	12/04/18	4-1	Removed Reference to Zero Temp Calibration.
1.30	09/17/19	1-6	Added Reference to USB Serial Port. Removed Reference to Modem.
1.40	02/26/2020	2-3	Correct Terminal Block Label for Alarm Horn.

Conventions and Symbols

Special characters, listed and described below, are used in this documentation to emphasize certain information.



Note: Emphasizes additional information pertinent to the subject matter.



Warning: Emphasizes information about actions which may result in personal injury.



Caution: Emphasizes information about actions which may result in equipment damage.

The following electrical symbols may be used in this documentation.

Symbol

Meaning



Direct current.



Alternating current.



Both direct and alternating current.



Earth (ground) terminal.



Frame or chassis terminal.

General Limited Warranty

Warranty

1. In no event will RODI Systems Corp., or any of its representatives, be responsible or liable for indirect or consequential damages resulting from the use or application of any product. The user and those responsible for applying the product must satisfy themselves with the acceptability of the application.
2. RODI Systems Corp. extends a one (1) year warranty covering parts and labor on any factory manufactured product. Any product, which is found to have a defect in workmanship or components, shall be replaced or repaired at the option of RODI Systems Corp.
3. A prepaid minimum inspection fee is required for the repair of products not covered by the warranty period. Contact RODI Systems Corp. for repair information and repair rates.
4. RODI Systems Corp. will not be responsible for replacement or repair of any product that was damaged by improper installation, mishandling, or user modifications.
5. All units returned for repair must have a RA (return authorization) number obtained from RODI Systems Corp. This RA number must be included with the returned product and any correspondence regarding the returned product must reference that number. Shipping on all returned products must be pre-paid and insured. RODI Systems Corp. will not be responsible for any shipping damage incurred. Repaired products will be shipped pre-paid and insured.
6. RODI Systems Corp. reserves the right to change any specification or feature of any product at any time. This right also extends to repair fees or any warranty conditions contained herein.



Control systems utilizing microprocessors and software should never be used in applications where the failure of such a system could endanger human life or cause injury. Emergency stops and other fail-safe controls should be hardwired into the control system, not interfaced with microprocessor control systems. If the equipment is not used in a manner as specified in this installation and operating manual, the safety features designed into this product may be impaired.



IMPORTANT NOTE: The AL250-V2 is powered via a multi-tap transformer which allows it to operate on the following primary voltages (acceptable range):

**115 VAC (108-130 VAC)
208 VAC (187-220 VAC)
230 VAC (216-254 VAC)**

Voltages outside of these values will damage the AL250-V2 power circuitry. Check primary line voltage before connecting power to the AL250-V2. Do not alter factory wiring in the AL250-V2. In areas susceptible to electrical surges, use an appropriate surge protector on the primary side of the transformer (See Appendix B).

AL250-V2 Overview	1-1
Introduction	1-1
Features	1-1
Specifications	1-2
Outputs	1-2
Inputs	1-3
Mode	1-4
Controls	1-5
Expansion Port	1-5
Serial Port	1-5
Data Logging	1-6
Installation	2-1
Environmental	2-1
Mounting	2-1
Ground	2-2
Connections	2-2
Power	2-2
I/O	2-3
Outputs	2-3
Inputs	2-4
Conductivity	2-5
Operation	3-1
Controls	3-1
Keypad	3-1
LED Indicators	3-2
Sequence	3-3
Screens	3-3
Main Menu	3-3
Status Screen	3-3
Quality Screen	3-3
Alarm Log	3-3
Settings Screen	3-3
Settings Table	3-4
Sanitization Lock	3-7
Diagnostic Screens	3-7
Time Delays	3-8
Calibration	4-1
Introduction	4-1
Conductivity Calibration	4-1
Troubleshooting	4-2
Temperature Calibration	4-2
Troubleshooting	4-3
Troubleshooting	5-1
Appendix A- Menu Diagram	
Appendix B - Technical Notes	

AL250-V2 Overview

1

Introduction

The AL250-V2 Reverse Osmosis Controller is designed to control and monitor the operating parameters of a single pump reverse osmosis water purification system. Information is displayed on a back-lit liquid crystal display, and on individual light-emitting diodes (LED). Functions and controls are operated through switches on the keypad.

Features

The AL250-V2 incorporates the following features:

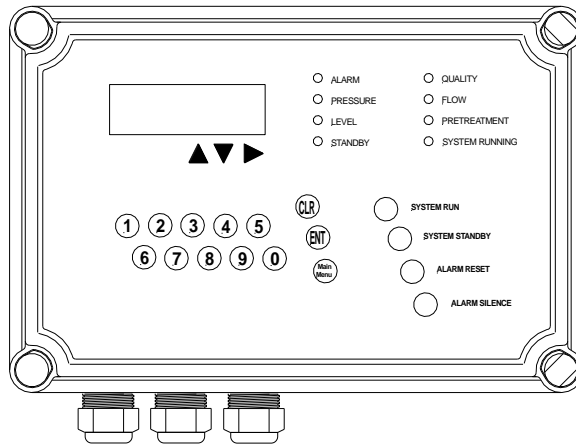

- Temperature Compensated Conductivity Monitor with Percent Rejection and Adjustable Alarm Setpoint
- Water Temperature Monitor with Adjustable High Temperature Shutdown
- Three Modes of Operation: Stand-by, Tank Feed, and Direct Feed
- Pretreatment Interlock
- High Tank Level Shutdown
- Low Tank Level Restart
- Inlet Valve Control
- Chemical Feed Pump Control
- Pump Control
- Low Feed Pressure Switch Sensing with Automatic Reset
- High Pressure Switch Sensing
- Autoflush with Adjustable Flush Interval and Duration
- Permeate Diversion Valve Output
- Alarm Output
- Optional Inputs for Analog Pressure Sensors
- Option Inputs for Sinking Pulse Flow Sensors
- Data Logging (Requires Optional AquaGraph™ Software and Serial Cable)
- Ports for Expansion and Serial Communication

Specifications

The AL250-V2 incorporates the following specifications:

Power Requirements: The controller can operate with following primary voltages (acceptable range). Depending upon the voltage being used, the power must be wired to the proper position on the power terminal strip near the transformer.



115 VAC (108-130 VAC)
208 VAC (187-220 VAC)
230 VAC (216-254 VAC)

Voltages outside of these values will damage the AL250-V2 power circuitry. Check primary line voltage before connecting power to the AL250-V2.

Environment: The controller can operate at a temperature from 0° to 55° C (32° to 131° F). Relative humidity must not exceed 95 percent. **Do not mount controller in direct sunlight.**



Conductivity Monitor: The conductivity monitor measures the feed and product water quality and displays this information in uS/cm. The value is temperature compensated to 25° C (77° F). The controller calculates and displays the salt rejection of the system (as a percentage).

Outputs

The AL250-V2 is equipped with the following outputs. The 24 VAC outputs are in the form of solid state triac outputs.

Inlet Solenoid: A 24 VAC output is provided to power the inlet solenoid valve. This output always energizes 15 seconds before the pump turns on, and de-energizes 15 seconds after the pump turns off. All water systems equipped with this controller are also equipped with a compatible inlet solenoid valve. If the valve must be replaced it must function on 24 VAC and have a current load less than one ampere.

AutoFlush Valve: A 24 VAC output is provided to power the reject (Autoflush) solenoid valve. This output will energize during the flush cycle thus opening the valve and allowing flow to bypass the reject control valve. If the valve must be replaced it must function on 24 VAC and have a current load less than one ampere.

Chemical Injection Pump: A 24 VAC output is provided to control a chemical injection system. This output energizes before the main pump starts and de-energizes before the main pump shuts down. This output is intended to power a relay or some other low current device.

Motor Starter: A 24 VAC output is included to provide controlled pump operation. This output powers the coil of the magnetic starter relay. This output is energized depending on other operating parameters. This output also has a maximum current rating of one ampere.

Permeate Diversion Valve: This is also a 24 VAC output. When the percent rejection of the system is below the setpoint, this output will be energized. This output is also energized during a flush. This output will power a relay, which will control an electric actuator. The maximum current available is one ampere.

Alarm: This consists of a 12 VDC output powering 108 db alarm horn mounted inside the AL250-V2 enclosure. A dry contact relay (2 amps resistive) is also provided for signaling external devices. The horn and relay are energized when the following conditions are present:

- Low Supply Pressure Shutdown
- High Membrane Feed Pressure Shutdown
- High Feed Water Temperature Shutdown
- Low Salt Rejection Shutdown
- Output or Transformer Overload
- High Differential Pressure Shutdown (when using analog sensors)
- High Permeate Pressure Shutdown (when using analog sensors)
- High and Low Flow Recovery Shutdown (when using flow sensors)

All 24 VAC outputs are protected by positive temperature coefficient resistors (polyfuses). The polyfuses interrupt the current to the AL250-V2 outputs should an overload condition occur on an output. The polyfuses will reset when power is turned off to the AL250-V2 and the fuse is allowed to cool. This eliminates the need for replaceable fuses and prevents damage caused by the incorrect fuse being installed. The primary side of the transformer in the AL250-V2 is also protected by a polyfuse. The AL250-V2 will indicate an overload condition for each output. It will also indicate an overload condition if the power to the AL250-V2 is interrupted within five seconds after any of the six outputs have been activated. In this way, the AL250-V2 can detect an overload in the transformer.

Inputs

The AL250-V2 is equipped with the following inputs:

Conductivity Sensors: There are five inputs for each conductivity sensor, two for the temperature detector (RTD), two for the electrodes in the conductivity cell, and one for the cable shield. Inputs are available for both the feed and product sensors. Sensors with cell constants of 0.01, 0.1, 1.0, and 10.0 may be used. These cell constants provide a detection range of 1 uS/cm to 100,000 uS/cm. Only sensors with a 1000 ohm RTD will work with this controller.

Pressure Sensors: There are four 4-20 mA inputs for pressure sensors monitoring feed pressure, interstage pressure, reject pressure, and permeate pressure. Differential pressures are calculated from feed pressure less interstage pressure and interstage pressure less reject pressure. If not used, these pressure inputs may be disabled in the settings menu.

Flow Sensors: There are three inputs for sinking pulse flow sensors. One sensor is configured for feed or permeate flow, one sensor is configured for recycle flow, and one sensor may be configured for either reject or permeate flow. Percent recovery is calculated from feed and permeate flow. If not used, these flow inputs may be disabled in the settings menu.

Low Pressure Switch: This is a dry contact that signals the system to shut down if the pump suction (supply) pressure falls below the desired value. This is a normally closed contact (when system is shut down). When a circuit is not complete between the two terminals, the system will operate. If contact is made between the two terminals, the system will shut down. An LED will indicate when the system is in a state of low pressure shut down. The system will attempt to restart every thirty seconds. The system will make up to five attempts at restarting. The system must be able to run continuously for thirty seconds without sensing low pressure. If the controller still senses low pressure after the fifth restart, it will lock out and the alarm reset button must be pressed to resume operation.

High Pressure Switch: This is a dry contact that signals the system to shut down if the pump discharge or membrane pressure exceeds the desired value. This is a normally open contact. When an open circuit condition exists between the two terminals, the system will operate. If contact is made between the two terminals, the system will shut down. An LED will indicate when the system is in a state of high pressure shut down. The alarm reset button must be pressed to resume operation after a shutdown due to high pressure.

Tank Level: The controller has two inputs that accept the dry contacts for the high level and low tank level switches. If the controller is in the “Tank Feed” mode (see the “Settings menu” section of this manual for further discussion), these switches read the water level in the RO product storage tank and turn the pump ON or OFF depending on the level. Each switch should be installed in the tank so that the contacts close when the water level falls below that particular switch. When the tank is full, the RO pump is turned off and the “Tank Full” LED is on continuously. As the tank is drawn down, the LED blinks. The LED turns off when the RO pump restarts to fill the tank (2 level switch operation).



The AL250-V2 may be configured to use only one tank level (high tank level) switch. Again the system must be operated in the “Tank Feed” mode (see the “Settings menu” section of this manual for further discussion). When this configuration is being used; the “Tank Full” LED will indicate when the system is in a state of high tank level (level switch open). The system starts and stops based only upon high tank level and the “High Tank Startup Delay” setpoint. When the level drops (the switch closes), the system will re-start after the “High Tank Startup Delay” (see “Settings Menu” section of this manual for further discussion). The “Tank Full” LED will blink while the “High Tank Startup Delay” timer is timing.

Pretreatment Interlock: This is a dry contact that signals the system to shut down when a pretreatment device is not functioning or regenerating. This could be used on a water softener, multimedia filter, chemical feed pump, pressure differential switch on prefilters, etc. This contact is normally closed. When a circuit is complete between the two terminals the system will operate. If contact is broken the system will shut down. An LED will indicate when the system is shut down due to pretreatment interlock. The system will restart itself when the contact is closed.

Chemical Pump Failure: This is a dry contact that signals the failure of the chemical injection system. This input differs from the “Pretreatment Interlock” in that it does not allow the system to restart. This contact is normally open. When an open circuit condition exists between the two terminals, the system will operate. If contact is made between the two terminals, the system will shut down. An LED will indicate when the system is shut down due to chemical pump failure.



All input connections on the AL250-V2 provide a supply voltage and are designed for dry contacts. **Do not apply voltage to the inputs as permanent damage may result.**

Mode

The AL250-V2 is designed to operate in one of three modes. The mode of operation is selected from the Settings menu.

The **stand-by mode** is intended to place the system in a temporary non-operational mode. When the system is placed in this mode, it will

perform a flush as scheduled by the amount of time entered for “Flush Interval” in the Settings data entry screen (See “Settings” section of this manual). The Flush Interval is the number of minutes between flushes. The Flush Duration is the total time in seconds that unit flushes. During a flush, the inlet, autoflush, and diversion solenoid valves are open and the high pressure RO pump and chemical pump (if applicable) are both running. The % Salt Rejection alarm is not activated during a flush. When the flush is complete, the pump will turn off and the inlet, flush, and diversion valves will close. The system will repeat this cycle based upon the time entered in the Flush Interval. (If the Flush Interval is set for zero the system will only flush on start up.) When the system is flushing, the amount of time remaining in the flush cycle will be indicated on the third line of the display. When the system is idle, the amount of time remaining until the next flush will be indicated.

The **tank feed mode** is intended to place the system in an operational mode when feeding a storage tank. When in this mode the system will shut down when the high tank level switch (not provided) has an open contact. The system will restart when the low level switch closes or after the High Tank Startup Delay interval if the system is not equipped with a low level tank switch (See “Settings” section of this manual). The flush cycle is also enabled in this mode. The controller will activate a flush when the system starts and at intervals while the tank is full. The Flush Interval and Duration are entered in the Settings menu (See “Settings” section of this manual). If the Flush Interval is set for zero the system will only flush on start up. When the system is autoflushing, the amount of time remaining in the flush will be indicated on the third line of the display.

The **direct feed mode** is intended to place the system in an operational mode when the system is feeding a distribution loop or another piece of equipment. In this mode the system will not flush and the tank level switch(es) is/are disregarded. When the system is in this mode, the total number of hours the system has been operated will be indicated on the last line of the display.



NOTE: Standby mode is selected from the Operating Mode screen (selection “1” from the Settings screen). Tank or Direct feed operation is selected from first setting (Index 0) from the list of settings accessed by selecting “2” from the Settings screen.

All three modes of operation are controlled by the System Start and System Stop keys. For example, if the system is put in *standby mode* and the System Start key is not pressed, the RO unit will not operate the flush cycles. This is the same for *tank feed* and *direct feed modes*, if the System Start key is not pressed, the RO unit will not operate. The system automatically stops the RO unit whenever a change between tank feed/direct feed and standby modes is made, requiring the operator to restart the RO unit. “SYSTEM STOP” key must be pressed prior to changing between tank feed and direct feed operation.

Controls

The AL250-V2 is equipped with the following controls and indicators.

- 4 x 20 LCD with LED Backlight
- Eight LED Indicators for Alarms and Status
- 20 Tactile Keys for Control and Data Entry

-
- Expansion Port** The AL250-V2 is equipped with one RS-485 expansion port which allows it to be networked into a larger water treatment monitoring system via Modbus RTU. The RS-485 expansion port is the 6 pin, watertight connector located in the upper right hand corner of the left hand side of the AL250-V2 enclosure.
- Serial Port** The AL250-V2 is equipped with one USB serial port located directly below the RS-485 expansion port on the left hand side of the AL250-V2 enclosure. Connecting to the serial port requires a PC computer with a USB port and a USB 2.0 Type A to USB Mini-B serial cable.
- Data Logging** The AL250-V2 is designed to log data from the RO system. This data may be retrieved locally through the serial port connection. Retrieval of logged data requires the use of AquaGraph™ PC software and serial cable described above.
-

Environmental The AL250-V2 is equipped with a NEMA 4X enclosure for use in industrial environments subject to occasional exposure to water sprays and other wet conditions. The AL250-V2 should not be used in explosive environments. General environmental specifications are listed below. **DO NOT mount controller in direct sunlight.**

Environmental Specifications	
Specification	Rating
Storage Temperature	-20 to 70 Deg C
Ambient Operating Temperature	0 to 55 Deg C
Ambient Humidity	30% to 95 % Relative Humidity (Non-Condensing)

Mounting The AL250-V2 is designed to be mounted in a horizontal position on a flat surface by means of four mounting holes. Opening the front cover of the enclosure allows access to the mounting holes, access to the bottom holes requires temporary removal of the hinge assemblies. When mounting the AL250-V2, sufficient room should be allowed on the side and bottom of the device for access to the I/O and serial port connections. Mounting dimensions are shown below.

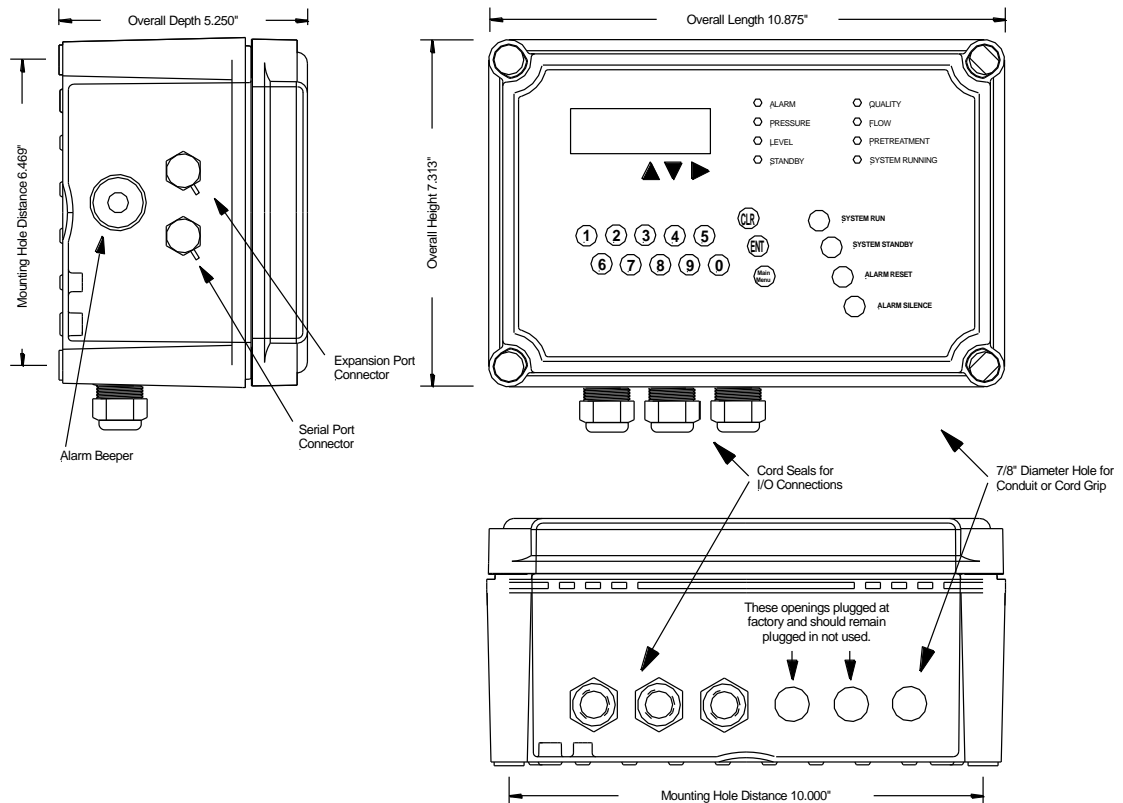

Ground

A good common ground reference (earth ground) is essential for proper operation of the AL250-V2. A good earth ground or power circuit ground should be connected to the ground terminal block I on the enclosure backpanel.

Connections

Screw terminals are provided for making connections for sensor inputs and power. Sensor and I/O terminals are located on the inside of the door of the AL250-V2 enclosure. The terminals are numbered in ascending order from left to right. Power terminals are on the backpanel of the enclosure. Power should always be disconnected from the AL250-V2 before making or changing any connections on these terminals.

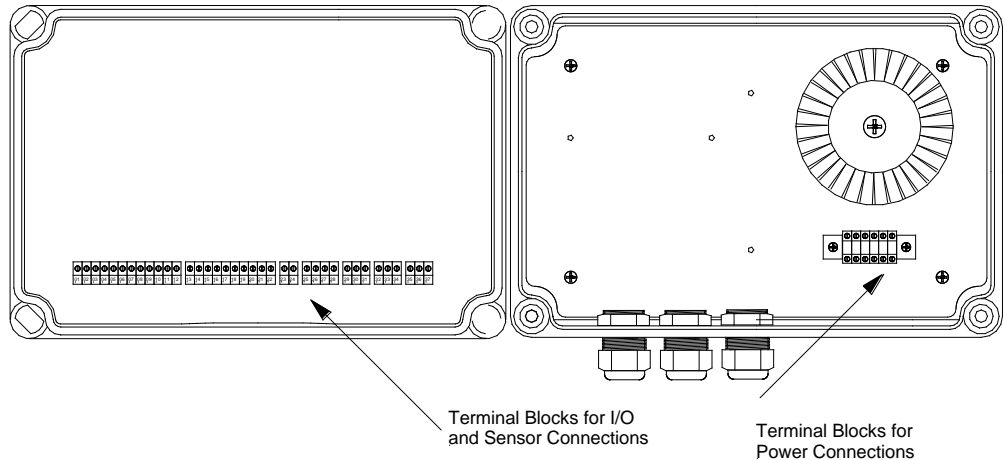

Power

The incoming power is connected on the terminal blocks just below the transformer on the backpanel of the enclosure. The triple tap transformer will accept 115, 208, or 230 volts AC (50 or 60 Hz). Depending upon the voltage being used, the power is connected to one of three terminals as illustrated. If 460 VAC is the only power source available, use a separate step-down transformer to lower the voltage to 230 VAC.

The AL250-V2 transformer is equipped with an internal thermal fuse on the primary winding to prevent damage from overloads.

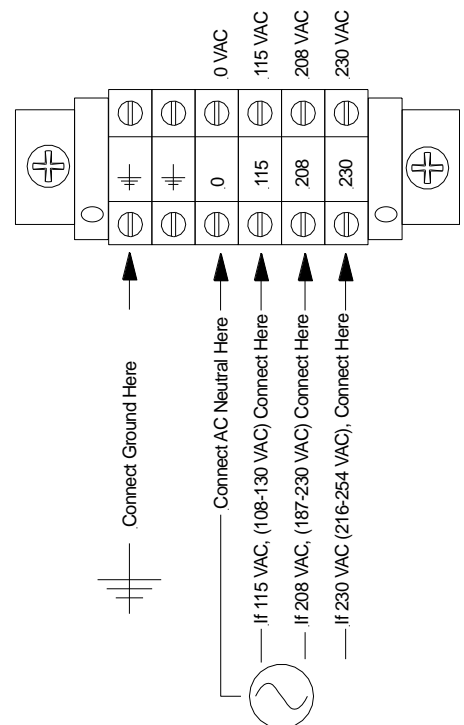

Always replace the terminal block cover after making the power connection.



Verify line voltage and check primary wiring (diagram at right) before applying power to the AL250-V2. Primary voltages outside of the ranges shown at right will result in damage to the AL250-V2 circuitry.



In locations subject to transient power surges, use a surge protector on the primary connections to the transformer. See Appendix B for more information on surge protection.

I/O



The connections for the inputs and outputs are shown below. Avoid using excessively large wire (larger than 18 AWG) on the inputs and outputs since it may prevent the enclosure door from closing properly. All wires from the inputs and outputs must pass through the grommet in the cord seal. Any unused openings in the grommet must be sealed with plugs to maintain the watertight characteristics of the enclosure.

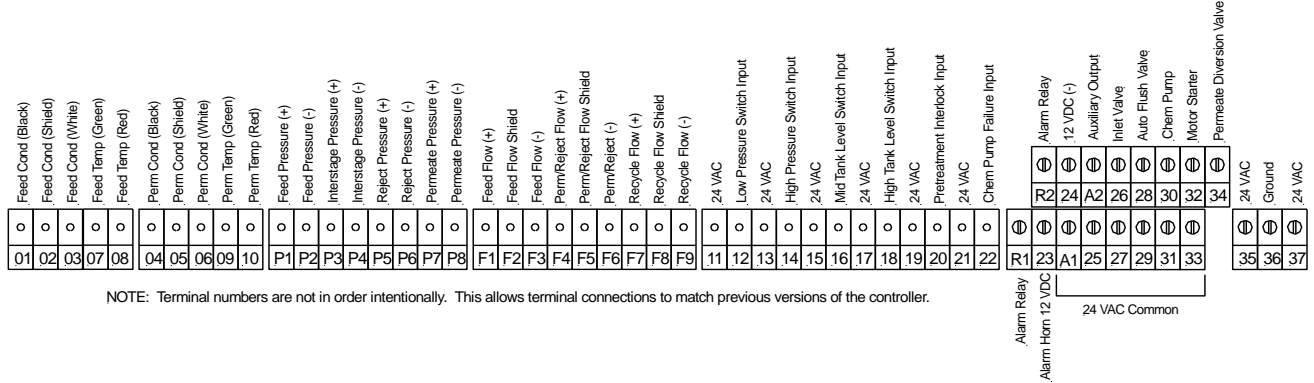

Outputs

All outputs (with the exception of the external alarm) are 24 VAC, one amp maximum. Any device connected to an output should be rated for less than one amp at 24 VAC. An overload on any output will cause current to be interrupted to the output and an alarm condition will occur. If the transformer supplying the controller becomes overloaded, the controller will reboot. If the overload still exists after the controller reboots, the controller will shut down the system and log an overload alarm.



The discrete outputs on the AL250-V2 are 24VAC only. The output loads (e.g., solenoid valves) cannot be bussed to the incoming power supply neutral (See figure on page 2-4). Two wires for each output must be connected to the load device from the AL250-V2.

Inlet Solenoid: A 24 VAC output is provided to power the inlet solenoid valve. The valve must function on 24 VAC and have a current load less than one ampere or otherwise be powered by an interposing relay.

AutoFlush Valve: A 24 VAC output is provided to power a reject (Autoflush) solenoid valve. This output will energize during the flush cycle thus opening the valve and allowing flow to bypass the reject control valve. The valve must function on 24 VAC and have a current load less than one ampere or otherwise be powered by an interposing relay.

Chemical Injection Pump: A 24 VAC output is provided to control a chemical injection system. This output is intended to power an interposing relay or some other low current device interfaced with the pump.

Motor Starter: A 24 VAC output is included to provide controlled pump operation. This output powers the coil of the magnetic starter relay if rated at one ampere or less. Other loads will require an interposing relay.

Permeate Diversion Valve: This is also a 24 VAC output. When the percent rejection of the system is below the setpoint, this output will be energized. This output is also energized during a flush. This output will power a relay, which will control an electric actuator. The maximum current available is one ampere.

Alarm: This consists of a 108 db alarm horn mounted inside the AL250-V2 enclosure. A separate alarm output connection provides a dry relay contact rated on 2 amps.

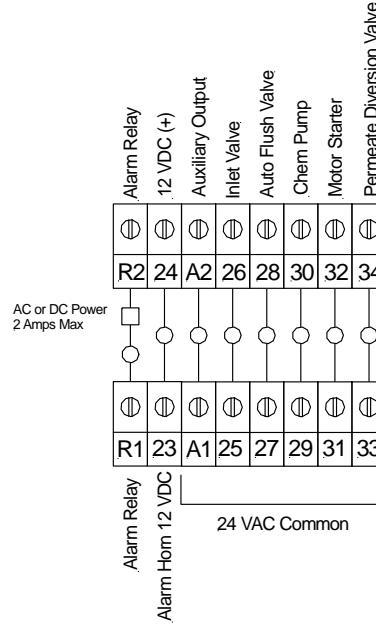

Incorrect Wiring

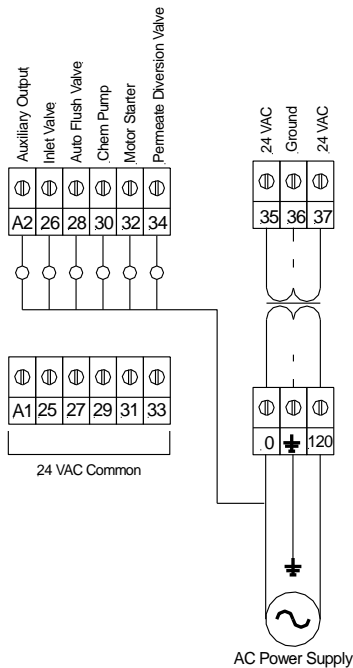

The solenoid coils are referenced to high voltage power supply.

DO NOT BUSS TO THE INCOMING POWER SUPPLY NEUTRAL.

Correct Wiring

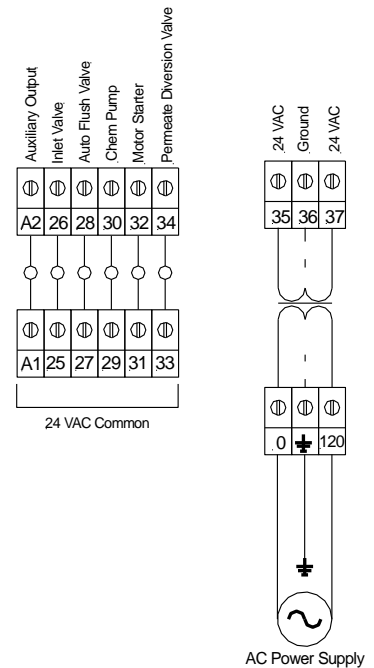

The outputs are referenced to 24VAC after the 24 VAC transformer.

USE TWO CONNECTIONS FOR EACH OUTPUT.

Analog Pressure Inputs

All inputs are designed for 4-20 mA isolated sensors. Excitation voltage to the sensors is supplied by the AL250-V2.

Feed Pressure Sensor: This sensor monitors the pressure of the water being fed to the inlet of the pressure vessel array.

Interstage Pressure Sensor: This sensor monitors the pressure of the water between the first and second stage arrays. First stage differential pressure is calculated by the AL250-V2 as the feed pressure less the interstage pressure.

Reject Pressure Sensor: This sensor monitors the pressure of the water exiting the second stage array. Second stage differential pressure is calculated by the AL250-V2 as the interstage pressure less the reject pressure.

Permeate Pressure Sensor: This sensor monitors the pressure of the permeate.

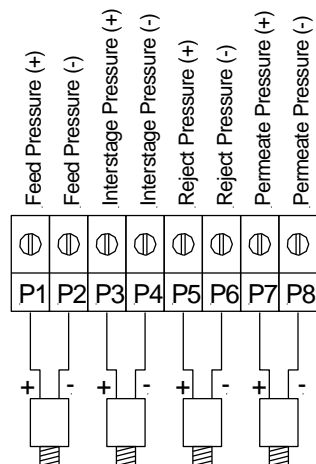

Flow Inputs

All inputs are designed for sinking pulse isolated sensors. Excitation voltage to the sensors is supplied by the AL250-V2.

Feed Flow Sensor: This sensor monitors the feed flow entering the RO system.

Permeate or Reject Flow Sensor: This sensor is configured in the settings menu to monitor either permeate or reject flow. Flow recovery is calculated based on feed flow and permeate flow.

Recycle Flow Sensor: This sensor monitors the flow of reject that is recycled back to the feed of the system.

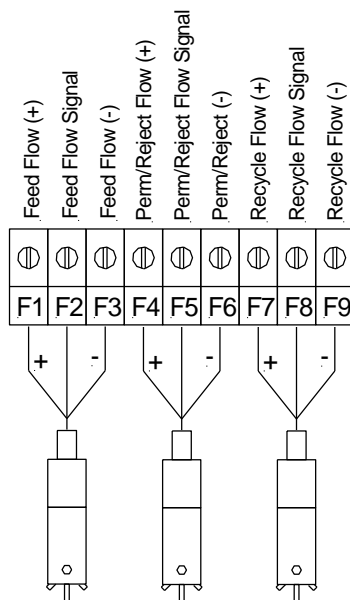

Discrete Inputs

All inputs should be dry contacts rated for 24 VAC. **Do not apply voltage to the inputs.** Input voltage to the contacts is supplied by the AL250-V2.

Low Pressure Switch: This is a dry contact that signals the system to shut down if the pump suction pressure falls below the desired value. This is a normally closed contact (when the system is shut down). When a circuit is not complete between the two terminals, the system will operate. If contact is made between the two terminals, the system will shut down.

High Pressure Switch: This is a dry contact that signals the system to shut down if the pump discharge or membrane pressure exceeds the desired value. This is a normally open contact. When an open circuit condition exists between the two terminals, the system will operate. If contact is made between the two terminals, the system will shut down.

Pretreatment Interlock: This input is designed to be normally closed. If a pretreatment interlock input is not being connected, a wire jumper must be installed between the two terminals at Input 5. Since the input is normally closed, multiple devices may be wired to this input in series.

Chemical Pump Failure:* This is a dry contact that signals the failure of the chemical injection system. This is a normally open contact. When an open circuit condition exists between the two terminals, the system will operate. If contact is made between the two terminals, the system will shut down.

Tank Level Switches: The AL250-V2 is designed to be used with one or two tank level switches. Switches should be wired in the normally closed position (the switch contacts close when the water level drops below the switch). When using two switches, a low-level tank switch starts the system (in Tank Feed mode) and a high-level switch stops the system. When using one switch, the switch connected must be a high-

level switch. The switch will stop the system at high level. When the level drops (the switch closes), the system will re-start after the “High Tank Startup Delay”, in minutes (See “Settings” section of this manual) that has been configured into the Settings data entry screen. The controller must be configured for one or two switch operation in the Settings menu (See “Settings” section of this manual).

Conductivity

The AL250-V2 is designed to monitor conductivity by means of a standard two electrode conductivity cell. Sensors with cell constants of 0.01, 0.1, 1.0, and 10.0 may be used. These cell constants provide a detection range of 1 uS/cm to 100,000 uS/cm. Only sensors with a 1000 ohm RTD will work with this controller.

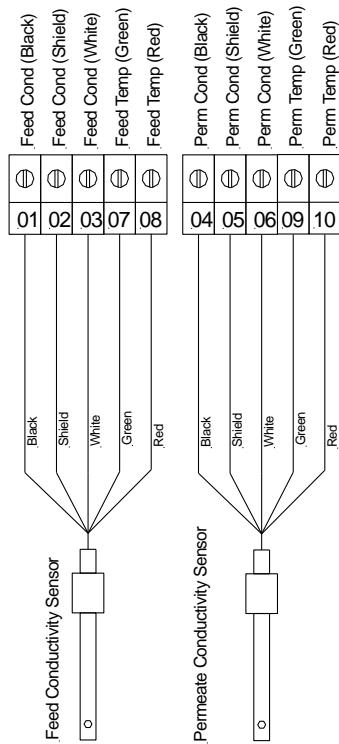

NOTE: Terminal numbers are not in order intentionally. This allows terminal connections to match previous versions of the controller.

Conductivity cells should be connected by means of Belden cable no. 8724 or equivalent. When routing the conductivity cables, stay clear of AC cables, motors, or other sources of electrical interference. Never run sensor cables in the same conduit with AC cables.

Controls

The AL250-V2 is housed in a NEMA 4X enclosure with a membrane keypad. Indicators include a 4 line x 20 character LCD with LED backlight and eight high intensity LED indicators for alarm conditions. The control features of the AL250-V2 are illustrated below.

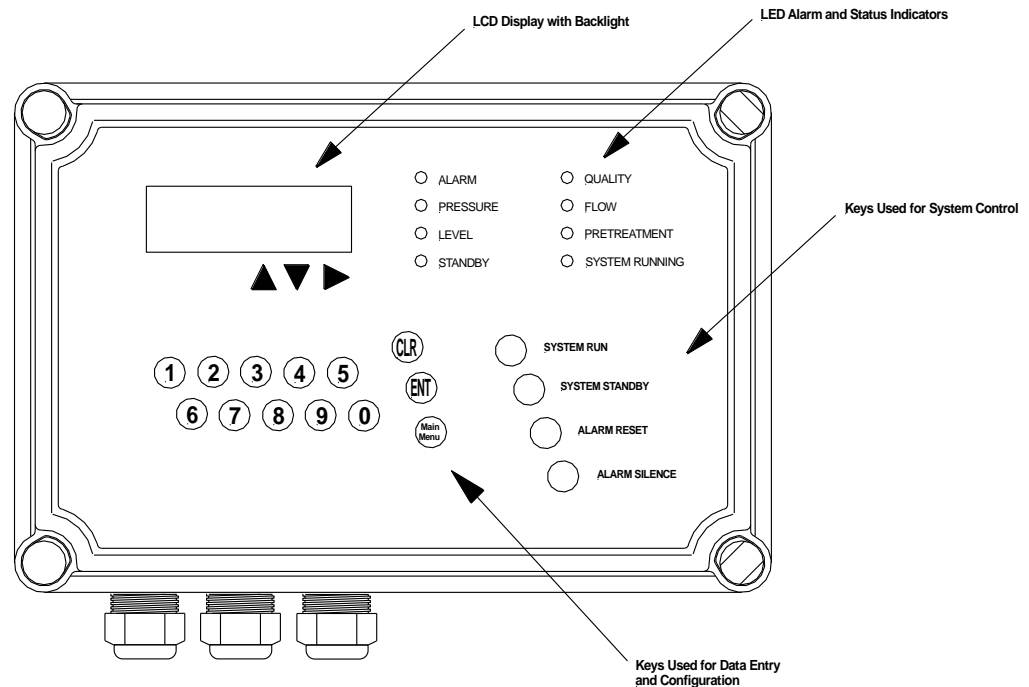

Keypad

The membrane keypad contains 20 tactile keys which are used for a number of control and data entry functions.

System Start: Pressing this key starts the system. If the Direct Feed mode has been chosen, pressing the System Start key immediately initiates the startup sequence. If the Tank Feed mode has been chosen, pressing this key will not initiate the startup sequence unless the tank is below high-level. Pressing this key in Stand-By mode will initiate the flush sequence of flush cycles.

System Stop: Pressing this key stops the system and essentially turns all functions off.

Alarm Reset: Pressing this key resets the system after an alarm shut down for low pressure, high pressure, low quality, high temperature, overload, or chemical injection failure (VANTAGE RO systems only).

Alarm Silence: Pressing this key silences the alarm horn for 120 seconds. The system will still shut down if the alarm condition does not correct itself before the shutdown delay expires (See “Settings” section of this manual).

Up Arrow, Down Arrow, Right Arrow: These keys are used to move through the display screens and for data entry purposes.

ENT: This key is used to confirm (ENTER) the various setting values.

CLR: This key is used to clear an erroneous data entry. The data must be cleared before pressing the ENT key.

Numbers 0-9: These keys are used for data entry as well as for accessing various screens directly or for making other selections.

LED Indicators

The eight LED indicators are used to indicate various status and alarm conditions.

Alarm: Indicates any current alarm condition.

PT/Chem Pump: Indicates when the system is experiencing failure of the chemical injection system. The system will shut down after the chem. pump failure time delay expires. Also, indicates when the system is shut down due to external pretreatment equipment.

Level: **LED Solid** - Indicates when the storage tank is full. **LED Blinking** – The tank level is transitioning between the High and Low Tank levels. The system will only shut down when in the Tank Feed mode.

Quality: Indicates that the percent rejection is below the alarm setpoint.

Flow: Indicates that a flow or recovery setpoint has been exceeded.

Pressure: Indicates that the system has experienced low pump feed pressure. The system will shut down after the low pressure time delay expires. The system will automatically restart up to five times after a low pressure shutdown. After the fifth attempt, the “ALARM RESET” key must be pressed before restarting. Also indicates that the system has experienced high pump or membrane pressure. The system will shut down after the high pressure time delay expires.

Standby: Indicates that the system has been placed in standby mode.

System Running: Indicates that the system is running in either tank feed or direct feed mode.

Sequence

The normal startup and shut down sequence for the system is listed below. In Direct Feed mode, this sequence is initiated when the System Start key is pressed. While in Direct Feed mode, the system will not shut down unless the System Stop key is pressed or an alarm occurs. In Tank Feed mode, this sequence will be initiated every time the system starts and stops as controlled by tank level. When in Tank Feed mode, this sequence will also be used for the autoflush cycles with the addition of the activation of the autoflush solenoid valve. When in Stand-By mode, this sequence is used for the autoflush cycles with the addition of the activation of the autoflush solenoid valve.

Startup

- Open Inlet Valve
- Open Autoflush Valve (during autoflush sequence only)
- Open Permeate Divert Valve
- Five Second Delay
- Start Chemical Feed
- Ten Second Delay
- Start Pump
- Close Auto Flush and Divert Valves (after the flush duration delay)

Shutdown

- Stop Pump and Chemical Feed
- Fifteen Second Delay
- Close Inlet Valve
- Close Autoflush Valve (if open)

The autoflush sequence is activated only in the Tank Feed and Stand-By modes of operation. Autoflush interval and duration are controlled by the interval and duration presets configured into the AL250-V2 in the Settings menu.

Screens

The AL250-V2 displays data and operating status by means of a number of screens displayed on the LCD. Specialized screens are also used for configuring the system and for entering setpoints, time delays, deadbands, etc. The screens displayed by the AL250-V2 are illustrated at the end of this manual.

Main Menu

The Main Menu consists of two screens which are accessed using the up and down arrow keys. The Main Menu screen displays the current operating mode, run status, and either hours since start (Direct Feed mode) or autoflush information (Standby mode). Only current operating mode and run status will be indicated while in Tank Feed mode. The Main Menu screen also allows the user to access other screens.

Status Screen

Status screen is accessed by pressing the number 2 on the keypad from the second Main Menu screen. The Status screen displays the total run time (RT) indicated as tenths of 1000 hours (As an example 0.2573 is the same as 257.3 hours).

Quality Screen

Quality screen is accessed by pressing the number 3 on the keypad from the second Main Menu screen. The Quality screen displays the feed conductivity (FCnd), permeate conductivity (PCnd), feed temperature (in degrees C), and percent rejection (%SR).

Alarm Log

Alarm Log screen is accessed by pressing the number 4 on the keypad from the second Main Menu screen. The user may tab through the alarm log by using the up and down arrow keys. The Alarm Log will hold up to 256 alarms along with the time and date of the alarm. In the event that Alarm Log needs to be cleared, press the right arrow key on the keypad. The user is prompted for the access code to clear the Alarm Log (factory default access code = 12345).

Settings Screen

Settings screen is accessed by pressing the number 5 on the keypad from the second Main Menu screen. The Settings screen itself has six selections. The first selection, number 0 on the keypad, allows the user to set the time (hours, minutes and seconds), date (day, date, month and year) access (factory default access code = 12345) and sanitize lockout (factory default sanitize lockout code = 12345) codes. The access code must be used to enter the Clock Settings screen or Main Settings screen. If the user re-enters either of these screens within 240 seconds of exiting, it is not necessary to enter the access code.

The AL250-V2 maintains time on a 24 hour clock (i.e., military style). The hours, minutes, and seconds are changed on separate screens by entering the appropriate number and pressing "ENTER". Date, month, and year are entered in the same fashion. The AL250-V2 also requires that the day of the week be entered (Sunday = 1, Saturday = 7).

The second selection from the Settings Screen, number 1 key, allows the user to change the operating mode of the AL250-V2; Sanitize, Standby or Operating (Tank/Direct Feed) modes. The third selection, number 2 key, allows access to the Settings data entry screens. The user is prompted for the access code to enter sub menu 0 (Clock) or 2 (Settings) of the Settings screen (factory default access code = 12345).



NOTE: Standby mode is selected from the Operating Mode screen (selection “1” from the Settings screen). Tank or Direct feed operation is selected from first setting (Index 0) from the list of settings accessed by selecting “2” from the Settings screen.

The fifth selection, number 4 key, allows the user to select the data log interval. The sixth selection, number 5 key, erases the data currently in the data logger.

Upon entering the Settings data entry screens (by pressing “2” from the main Settings screen), the user will have the option of entering an index number for a particular setting. This enables the user to go directly to a particular setting without scrolling through the entire list of settings. Alternatively, the user may scroll through the settings with the up and down arrow keys.

Settings Table

The table below lists the index number of all of the Settings data entry screens, the abbreviation used on the screen, the full name of the setting, and any other pertinent information on that particular setting. **NOTE:** Where required, the right arrow key is used to enter the decimal point.

AL250-V2 Settings						
Index	Screen Name	Full Name	Range	Format	Default Setting	Details
0†	Feed	Tank or Direct Feed	0 or 1	0	1	Allows the user to choose between tank feed and direct feed operation. Enter [0] for tank feed or [1] for direct feed.
1	Low Salt Rjct SP %	Low Salt Rejection Setpoint	0-100	00.0	90	Setpoint (in %) which activates the alarm for low salt rejection.
2	Low Salt Rjct DB %	Low Salt Rejection Deadband	0-20	00.0	0.5	Deadband (in %) through which the salt rejection value must increase to release the low salt rejection alarm.
3	Low Salt Rjct TDsec	Low Salt Rejection Time Delay	0-255	000	1	Delay (in seconds) before the low salt rejection alarm is activated once the current value falls below the setpoint.
4	Low Salt Rjct SDsec	Low Salt Rejection Shut Down Delay	0-255	000	1	Delay (in seconds) before the system shuts down after the low salt rejection alarm is activated.
5	Perm Divert SP %	Permeate Diversion Setpoint	0-100	00.0	80	Salt rejection setpoint (in %) which turns ON the “Divert to Drain” output.
6	Perm Divert DB %	Permeate Diversion Deadband	0-20	0.0	1.0	Deadband (in %) through which the salt rejection value must increase before the “Divert to Drain” output is turned off.
7	Perm Divert TD Sec	Permeate Diversion Time Delay	0-255	000	15	Delay (in seconds) before the permeate “Divert to Drain” output is turned ON, once the current value falls below the setpoint.
8	High Temp SP DegC	High Temperature Setpoint	0-45	00	32	Temperature setpoint (in deg C) which activates the high temperature alarm.

9	High Temp DB DegC	High Temperature Deadband	0.1-10	0.0	3	Deadband (in deg C) through which the temperature value must pass before the high temperature alarm is released.
10	High Temp TD Sec	High Temperature Time Delay	0-255	000	20	Delay (in seconds) before the high temperature alarm is activated once the current value rises above the setpoint.
11	High Temp Shtdwn Sec	High Temperature Shut Down Delay	0-255	000	10	Delay (in seconds) before the system shuts down after the high temperature alarm is activated.
12	High Tank Lvl TD Sec	High Tank Level Time Delay	1-255	000	5	Delay (in seconds) before the system shuts down for high tank level.
13†	Low Tank Switch EN	Low Tank Switch Enable	0 or 1	0	1	Allows the system to be configured with or without a low tank level switch. Enter [1] to enable (low tank level switch present) or [0] to disable (low tank level not being used) this feature.
14	Hi Tnk Startup Sec	High Tank Level Restart Time Delay	1-1000	000	30	Delay (in seconds) before the system will restart after the tank level drops below the high tank level switch. This feature is only used when the system is configured for operation without a low tank level switch.
15	Low Tank Lvl TD Sec	Low Tank Level Time Delay	1-255	000	5	Delay (in seconds) before the system restarts (in Tank Feed mode) when the level drops below the low tank level switch.
16	High Pressure TD Sec	High Pressure Shut Down Delay	0-255	000	5	Delay (in seconds) before the system shuts down for high pressure. This alarm is controlled by the high pressure switch discrete input.
17	Low Pressure TD Sec	Low Pressure Shut Down Delay	0-255	000	5	Delay (in seconds) before the system shuts down for low pressure. This alarm is controlled by the low pressure switch discrete input..
18	Overload TD Sec	Overload Time Delay	1-255	000	2	Delay (in seconds) before the system shuts down for output overload.
19	Prettr Intlk TD Sec	Pretreatment Interlock Time Delay	1-255	000	2	Delay (in seconds) before the system shuts down for pretreatment interlock.
20	Chem. Pump TD Sec	Chemical Pump Failure Time Delay	0-100	000	2	Delay (in seconds) before the system shuts down for failure of the chemical injection pump.
21†	Flush Interval Min	Auto Flush Interval	0-90	000	60	Interval (in minutes) between autoflush cycles. Interval flush is disabled if this value is set to "0".
22	Flush Duration Sec	Auto Flush Duration	1-360	000	180	Duration (in seconds) of each autoflush cycles.
23	Feed CND Standard	Feed Conductivity Standard	100-100,000	0000	NA	With these settings, the user can calibrate the conductivity inputs to a standard solution. See Calibration section for more information.
24	Perm CND Standard	Permeate Conductivity Standard	0-1,000	00.0	NA	
25	Feed Temp Span DegC	Feed Temperature Span Calibration	1-50	00.0	NA	This setting allows the temperature sensor in the feed conductivity cell to be calibrated to a known temperature at span value. Only qualified users following the procedures documented in the Calibration section of this manual should adjust this setting.

26	Perm Temp Span DegC	Permeate Temperature Span Calibration	1-50	00.0	NA	This setting allows the temperature sensor in the permeate conductivity cell to be calibrated to a known temperature at span value. Only qualified users following the procedures documented in the Calibration section of this manual should adjust this setting.
27	Feed Cond Range	Measurement Range of Feed Conductivity Sensor	0-7	0	0	These settings select the range for the conductivity inputs as follows: [7] 10,000-100,000 uS Using K=10.0 [6] 1,000-10,000 uS Using K=10.0 [5] 1,000-10,000 uS Using K=1.0 [4] 100-1,000 uS Using K=1.0 [3] 100-1,000 uS Using K=0.1 [2] 10-100 uS Using K=0.1 [1] 10-100 uS Using K=0.01 [0] 1.00-10.0 uS Using K=0.01 The proper cell constant must be used for the range selected.
28	Perm Cond Range	Measurement Range of Permeate Conductivity Sensor	0-7	0	0	
29	Press Activate	Pressure Input Activation	0 or 1	0	0	This setting activates all analog pressure sensor inputs and associated alarms. Pressure display screen is not accessible when pressure inputs are not activated. Enter [0] to deactivate pressures or [1] to activate pressures.
30	Press Config	Pressure Input Configuration	0 or 1	0	0	This setting configures the pressure inputs and associated alarms by activating or deactivating the interstage pressure input. Enter [0] to deactivate the interstage pressure or [1] to activate the interstage pressure. When deactivated DP1 is calculated by the difference between feed and reject pressures and DP2 is not calculated.
31	Feed Prss Span	Measurement Span of Feed Pressure Sensor	0-1,000	0000	100	Full scale span (psig) of the pressure sensor represented by a 20 mA output. The pressure input assumes 4 mA represents zero psig.
32	Intrstg Prss Span	Measurement Span of Feed Pressure Sensor	0-1,000	0000	100	
33	Reject Prss Span	Measurement Span of Feed Pressure Sensor	0-1,000	0000	100	
34	Perm Prss Span	Measurement Span of Feed Pressure Sensor	0-1,000	0000	100	
35	High Fd Prss SP	High Feed Pressure Setpoint	0-1,000	00	100	Pressure setpoint (in psig) which activates the high pressure alarm.
36	High Fd Prss DB	High Feed Pressure Deadband	0-100	0.0	10	Deadband (in psig) through which the pressure value must pass before the high pressure alarm is released.
37	High Fd Prss TD	High Feed Pressure Time Delay	0-255	000	20	Delay (in seconds) before the high pressure alarm is activated once the current value rises above the setpoint.

38	High Fd Prss Shtdwn	High Feed Pressure Shut Down Delay	0-255	000	10	Delay (in seconds) before the system shuts down after the high pressure alarm is activated.
39	High Prm Prss SP	High Permeate Pressure Setpoint	0-100	00	50	Pressure setpoint (in psig) which activates the high pressure alarm.
40	High Prm Prss DB	High Permeate Pressure Deadband	0-10	0.0	5	Deadband (in psig) through which the pressure value must pass before the high pressure alarm is released.
41	High Prm Prss TD	High Permeate Pressure Time Delay	0-255	000	20	Delay (in seconds) before the high pressure alarm is activated once the current value rises above the setpoint.
42	High Prm Prss Shtdwn	High Permeate Pressure Shut Down Delay	0-255	000	10	Delay (in seconds) before the system shuts down after the high pressure alarm is activated.
43	High DP1 Prss SP	High Differential Pressure Setpoint	0-100	00	50	Pressure setpoint (in psid) which activates the high differential pressure alarm.
44	High DP1 Prss DB	High Differential Pressure Deadband	0-10	0.0	5	Deadband (in psid) through which the pressure value must pass before the high differential pressure alarm is released.
45	High DP1 Prss TD	High Differential Pressure Time Delay	0-255	000	20	Delay (in seconds) before the high differential pressure alarm is activated once the current value rises above the setpoint.
46	High DP1 Prss Shtdwn	High Differential Pressure Shut Down Delay	0-255	000	10	Delay (in seconds) before the system shuts down after the high differential pressure alarm is activated.
47	High DP2 Prss SP	High Differential Pressure Setpoint	0-100	00	50	Pressure setpoint (in psid) which activates the high differential pressure alarm.
48	High DP2 Prss DB	High Differential Pressure Deadband	0-10	0.0	5	Deadband (in psid) through which the pressure value must pass before the high differential pressure alarm is released.
49	High DP2 Prss TD	High Differential Pressure Time Delay	0-255	000	20	Delay (in seconds) before the high differential pressure alarm is activated once the current value rises above the setpoint.
50	High DP2 Prss Shtdwn	High Differential Pressure Shut Down Delay	0-255	000	10	Delay (in seconds) before the system shuts down after the high differential pressure alarm is activated.
51	Flow Activate	Flow Input Activation	0 or 1	0	0	This setting activates all flow sensor inputs and associated alarms. Flow display screen is not accessible when Flow inputs are not activated. Enter [0] to deactivate flows or [1] to activate flows.
52	Flw1 Config	Configuration of Flow Sensor 1	0 or 1	0	0	This setting configures the use of the first flow sensor. Enter [0] to use the sensor on feed or [1] to use the sensor on permeate.

53	Flw2 Config	Configuration of Flow Sensor 2	0 or 1	0	0	This setting configures the use of the second flow sensor. Enter [0] to use the sensor on reject or [1] to use the sensor on permeate.
54	Flw1 K Fact	K Factor for Flow Sensor 1	0-10,000	0000.0	100	K factor (in pulses per gallon) for the first flow sensor.
55	Flw2 K Fact	K Factor for Flow Sensor 2	0-10,000	0000.0	100	K factor (in pulses per gallon) for the second flow sensor.
56	Flw3 K Fact	K Factor for Flow Sensor 3	0-10,000	0000.0	100	K factor (in pulses per gallon) for the third flow sensor.
57	High Recovery SP	High Flow Recovery Setpoint	0-100	00	90	Recovery setpoint (in percent) which activates the high pressure alarm.
58	High Recovery DB	High Flow Recovery Deadband	0-100	0.0	10	Deadband (in percent) through which the recovery value must pass before the high recovery alarm is released.
59	High Recovery TD	High Flow Recovery Time Delay	0-255	000	20	Delay (in percent) before the high recovery alarm is activated once the current value rises above the setpoint.
60	High Recovery Shtdwn	High Flow Recovery Shut Down Delay	0-255	000	10	Delay (in seconds) before the system shuts down after the high recovery alarm is activated.
61	Low Recovery SP	Low Flow Recovery Setpoint	0-100	00	90	Recovery setpoint (in percent) which activates the low pressure alarm.
62	Low Recovery DB	Low Flow Recovery Deadband	0-100	0.0	10	Deadband (in percent) through which the recovery value must pass before the low recovery alarm is released.
63	Low Recovery TD	Low Flow Recovery Time Delay	0-255	000	20	Delay (in seconds) before the low recovery alarm is activated once the current value drops below the setpoint.
64	Low Recovery Shtdwn	Low Flow Recovery Shut Down Delay	0-255	000	10	Delay (in seconds) before the system shuts down after the low recovery alarm is activated.

† System must be shut down to change these settings.

Diagnostic Screens

From the Main Menu <1> screen, the user may select a number of diagnostic screens. The following may be accessed from the Main Diagnostic screen:

Press "1" to view the serial number of the controller, software version, and serial port status.

Press "2" to view the raw analog values for conductivity and temperature.

Press "3" to view the status of the digital inputs. Use the Up and Down Arrow keys to view all of the inputs.

Press "4" to view the status of the digital outputs. Use the Up and Down Arrow keys to view all of the outputs.

Press "5" to check the operation of the keypad. Each key press will be displayed on the screen. Press the Main Menu key twice to return to the Main Menu.

IMPORTANT: System Start and System Stop keys do not function while in keypad diagnostic mode.

Time Delays

Time delays and deadbands are used to control the action of the AL250-V2 alarms. These are described below.

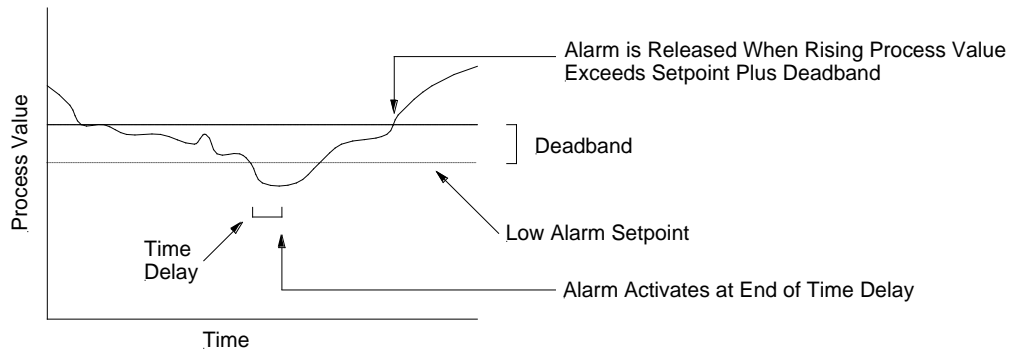

The illustration above shows the action of a low alarm setpoint on a falling value.

The high setpoint works in the same manner except the deadband is below the setpoint.

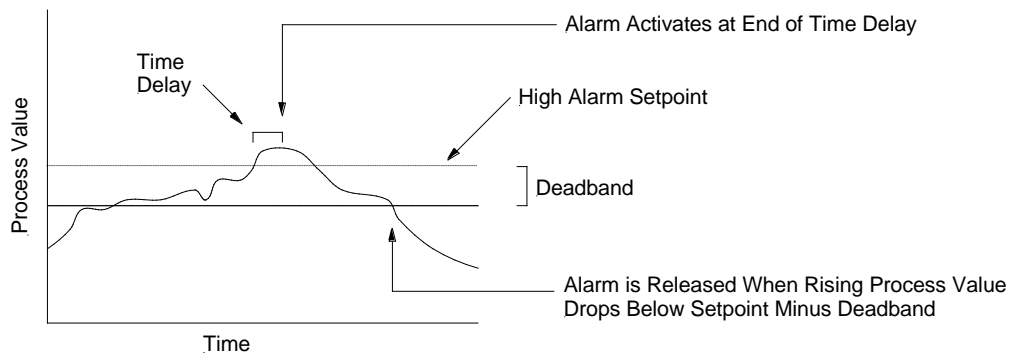

Introduction

A number of parameters monitored by the AL250-V2 must be periodically calibrated for optimum performance and accuracy. These are outlined below.

AL250-V2 Calibration			
Parameter	Method of Calibration	Settings Index Number	Recommended Calibration Frequency
Feed Conductivity	Calibration with Conductivity Standard Solution	23	One to Three Months Depending Upon Sample Condition
Permeate Conductivity	Calibration with Conductivity Standard Solution	24	
Feed Temperature Span	Calibration to Known Temperature	25	Six Months
Permeate Temperature	Calibration to Known Temperature	26	

Conductivity

The conductivity inputs of the AL250-V2 should be calibrated using a known standard solution. Value of the standard should be in the upper area of the range of the conductivity being measured by the AL250-V2.

In cases of low conductivity (< 50 uS/cm) it may be necessary to calibrate the sensor and its associated input channel in situ. This is done by following the same general procedure as outlined below for calibration to a standard solution with one exception. In situ calibration requires that the sensor be left mounted in the process line. Instead of using a standard solution, a sample from the process line is tested with a calibrated meter. This measured conductivity value of the process fluid is used in lieu of a standard solution value.

The following procedure should be used for calibrating the AL250-V2 to a solution of known conductivity.

Step One – Rinse or soak the sensor in deionized water. Dry the sensor and place it in a solution of known conductivity. This may be a standard solution provided a laboratory supply company or a water sample which has been measured by a calibrated conductivity meter. Make sure that the conductivity value of the calibration solution is within the upper range of the AL250-V2 conductivity channel. Allow the sensor to equalize to the solution temperature for a few minutes before proceeding with the next step.

Important



Please note:

- Temperature and conductivity are combined in one sensor.
- If temperature and conductivity are both being calibrated, always calibrate the temperature first.
- Be careful not to damage (avoid excessive twisting, bending, etc.) the sensor leads when removing the sensor from the pipe fitting.
- Never reuse standard solutions. Always dispense the solution from its container and dispose of the solution after using it.
- Use clean containers (triple rinsed with deionized water) for holding the calibration solution.

Step Two – Go to the appropriate Settings data entry screen (23 or 24). Enter the value of the calibration solution via the keypad. Press ENTER. A new measured value will appear on the screen.

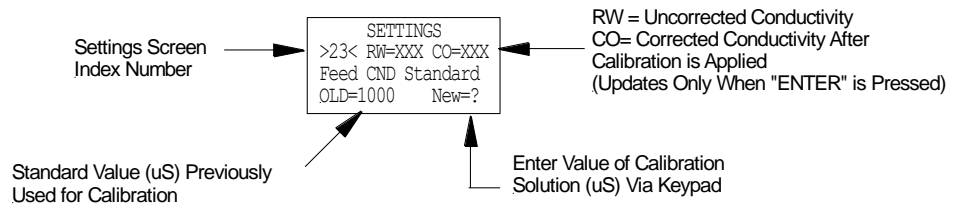

If the value displayed on the screen does not match the value entered for the calibration solution, let the sensor equalize for a few more minutes and repeat Step Two.

Troubleshooting

If problems occur during calibration, please check the following:

- Ensure that the Settings screen corresponds to the sensor being calibrated.
- Check the condition of the sensor. Make sure that the electrode surfaces are not damaged, corroded, or fouled.
- Make sure that the sensor is suitable for use with the AL250-V2. Verify that the cell constant is correct for the conductivity range selected and that the sensor is equipped with the proper temperature element (1000-Ohm Platinum RTD).
- Check the condition of the sensor wiring and that the sensor leads are properly connected to the AL250-V2 terminals.
- Verify that the calibration solution is the correct conductivity value and that the value is within the range selected of the conductivity input being calibrated.
- Refer to the Troubleshooting Section of the manual for more information.

Temperature

The temperature elements in the conductivity sensors are calibrated in a similar fashion as the conductivity sensors. Follow these steps for temperature calibration.

Step One – Place the conductivity sensor in a water sample at approximately the same temperature as that being monitored in the process. Measure the temperature with a laboratory grade thermometer. Allow the sensor to equalize to the solution temperature for a few minutes before proceeding with the next step.

Important



Please note:

- Temperature and conductivity are combined in one sensor.

- If temperature and conductivity are both being calibrated, always calibrate the temperature first.
- Be careful not to damage (avoid excessive twisting, bending, etc.) the sensor leads when removing the sensor from the pipe fitting.
- The conductivity standard solution may be used for temperature calibration when combining the temperature and conductivity calibrations.

Step Two – Go to the appropriate Settings data entry screen (25 or 26). Enter the temperature of the calibration solution via the keypad. Press ENTER. A new measured value will appear on the screen.

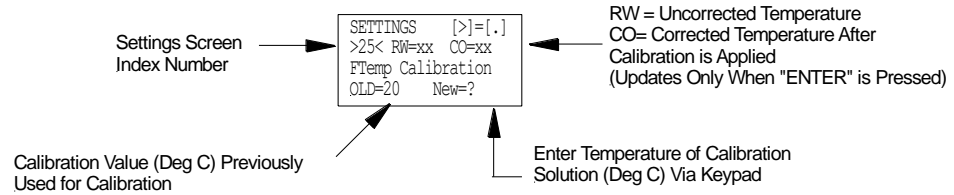

If the value displayed on the screen does not match the value entered for the calibration solution, let the sensor equalize for a few more minutes and repeat Step Two.

Troubleshooting If problems occur during calibration, please check the following:

- Ensure that the Settings screen corresponds to the sensor being calibrated.
- Check the condition of the sensor. Make sure that the electrode surfaces are not damaged, corroded, or fouled.
- Make sure that the sensor is suitable for use with the AL250-V2. Verify that the sensor is equipped with the proper temperature element (1000-Ohm Pt RTD).
- Check the condition of the sensor wiring and that the sensor leads are properly connected to the AL250-V2 terminals.
- Refer to the Troubleshooting Section of the manual for more information.

The AL250-V2 Reverse Osmosis Controller is designed for ease of maintenance and minimum service. Since the highest quality of electronic semiconductor components are used in this design, it is not likely that circuit malfunctions or failures will occur.

It is our experience that field failures which most frequently occur are:

- Improper or broken wiring connections
- Incorrect wiring of magnetic starter
- Improper grounding
- Cable run is too long
- Water in connectors
- Dirty cell electrodes
- Defective conductivity/temperature probes

The following table lists the problems commonly encountered when using the AL250-V2.

Problem	Probable Cause	Tests and Corrective Action
Nothing appears on the display and backlight is not illuminated.	No power.	Ensure that 115, 208 or 230 VAC is connected to the proper terminals on the terminal strip. Check for 24 - 30VAC on terminals #35 and #37. Voltage between #35 and ground or #37 and ground will be ½ of the total secondary voltage. Check for loose wires on circuit board.
The RO will not start when the start button is pressed. "SYSTEM OFF" is displayed on line 4 of the Main Menu.	AL250-V2 is in Standby Mode.	The AL250-V2 will not start the RO in the Standby mode. Review line 2 of the Main Menu display for a system MODE message.
	AL250-V2 is in pretreatment interlock.	If the pretreatment interlock input is OFF then the AL250-V2 will not start. The pretreatment interlock LED will be ON.

<p>The RO will not start when the start button is pressed.</p> <p>“SYSTEM ON” is displayed on line 4 of the Main Menu.</p>	<p>The product tank is full in Tank mode.</p>	<p>When the product tank is full the “Level” LED is on and the RO will not run until the level drops below the switch.</p>
	<p>The level switch is set as closed when product tank is full.</p>	<p>The tank level switch must be installed as open when the tank is full.</p>
	<p>AL250-V2 is in pretreatment interlock.</p>	<p>If the pretreatment interlock input is OFF then the AL250-V2 will not start. The pretreatment interlock LED will be ON.</p>
	<p>Controller is in Stand-By Mode and system is between auto flush cycles.</p>	<p>Review line 2 of the Main Menu for a system MODE message.</p>
	<p>Motor overload.</p>	<p>Check the high pressure pump for an overload relay trip.</p>
<p>Display does not respond to keypad entries.</p>	<p>Wrong screen on display.</p>	<p>Some keypad entries only function on certain screens (i.e., Arrow keys do not function on all displays).</p>
	<p>Damaged keypad.</p>	<p>Verify key operation by using Key Test in the Diagnostic screens.</p>
<p>AL250-V2 will not change between TANK mode and DIRECT mode.</p>	<p>Wrong screen.</p>	<p>To change between TANK mode and DIRECT mode use the settings menu and select settings screen #0. The operation mode cannot be changed from the MODE menu. The operation mode cannot be changed will the RO is running.</p>
<p>Conductivity reading is higher than known solution.</p>	<p>Conductivity cell not calibrated.</p>	<p>Re-calibrate conductivity channel using instructions in AL250-V2 manual.</p>
	<p>Temperature sensor damaged or loose wire on temperature sensor.</p>	<p>Review the raw analog values in the diagnostic screens. The RTD values must be less than 4095. Check the resistance across the red and green wires of BOTH sensors. The acceptable range is 1000 – 1187 Ohms.</p>
	<p>Air bubbles in sensing area.</p>	<p>Carefully loosen the compression ring until a small stream drips from sensor connection. DO NOT LOOSEN MORE THAN 3 TURNS. Review the conductivity reading while the sensor fitting drips. A correct reading indicates air bubble interference.</p>
	<p>Fouled sensor.</p>	<p>Remove the sensor and inspect for scale or foulant build up.</p>
	<p>Damaged conductivity sensor.</p>	<p>Swap the permeate and feed sensor. If the problem follows the sensor then replace the faulty sensor. Make sure that the temperature connections are swapped also.</p>

Conductivity reading is erratic.	Open circuit in temperature sensor.	Review the raw analog values in the diagnostic screens. The RTD values must be less than 4050. Check the resistance across the red and green wires of BOTH sensors. The acceptable range is 1000 – 1187 Ohms.
	Faulty sensor or faulty sensor wiring.	Swap the permeate and feed sensor. If the problem follows the sensor then replace the faulty sensor. Make sure that all temperature and conductivity connections are made.
	Moisture in cables.	Inspect cable sheathing.
Conductivity reading is inaccurate, especially at low conductivity values.	Conductivity cell not calibrated.	Re-calibrate conductivity channel using instructions in AL250-V2 manual.
	Wrong conductivity cell constant.	Make sure the conductivity cell has a cell constant consistent with the conductivity range being monitored.
Temperature readings show full scale.	Open circuit in temperature sensor.	Check for loose wire connections. Check resistance across the red and green wire of the suspect sensor. The resistance across these wires must be between 1000 and 1187 Ohms. If not then replace sensor.
AL250-V2 displays "Overload Alarm" when it is first powered.	General overload alarm event.	The AL250-V2 lost power within 5 seconds of ANY output turning ON. Press the "Alarm Reset" button. If the alarm returns after RO startup then review the alarm log to determine which output is overloaded.
Cannot clear or reset an alarm event.	Pressing wrong key.	Make sure that the ALARM RESET key on the right side of the enclosure face is pressed.
	Wrong menu selection.	The Alarm Log "clear" function does not clear or reset the individual alarm event. It only clears the historical log of all alarm events.
The LCD is backlit; however there is no text visible.	Faulty LCD.	Cycle power, allow the AL250-V2 to cool off and retry the operation.
	Excessive environment heat.	If the controller is installed outside, in direct sunlight or a hot environment the LCD can appear blank. Turn the AL250-V2 off and let it cool down. If the LCD screen text returns after the unit is cool then heat is the issue.

The AL250-V2 displays a low suction pressure alarm even though the suction pressure is OK.	Faulty pressure switch.	Test pressure switch.
	Switch not wired properly.	The AL250-V2 requires a closed circuit to indicate low suction pressure. Check wiring.

Appendix A - Menu Diagram

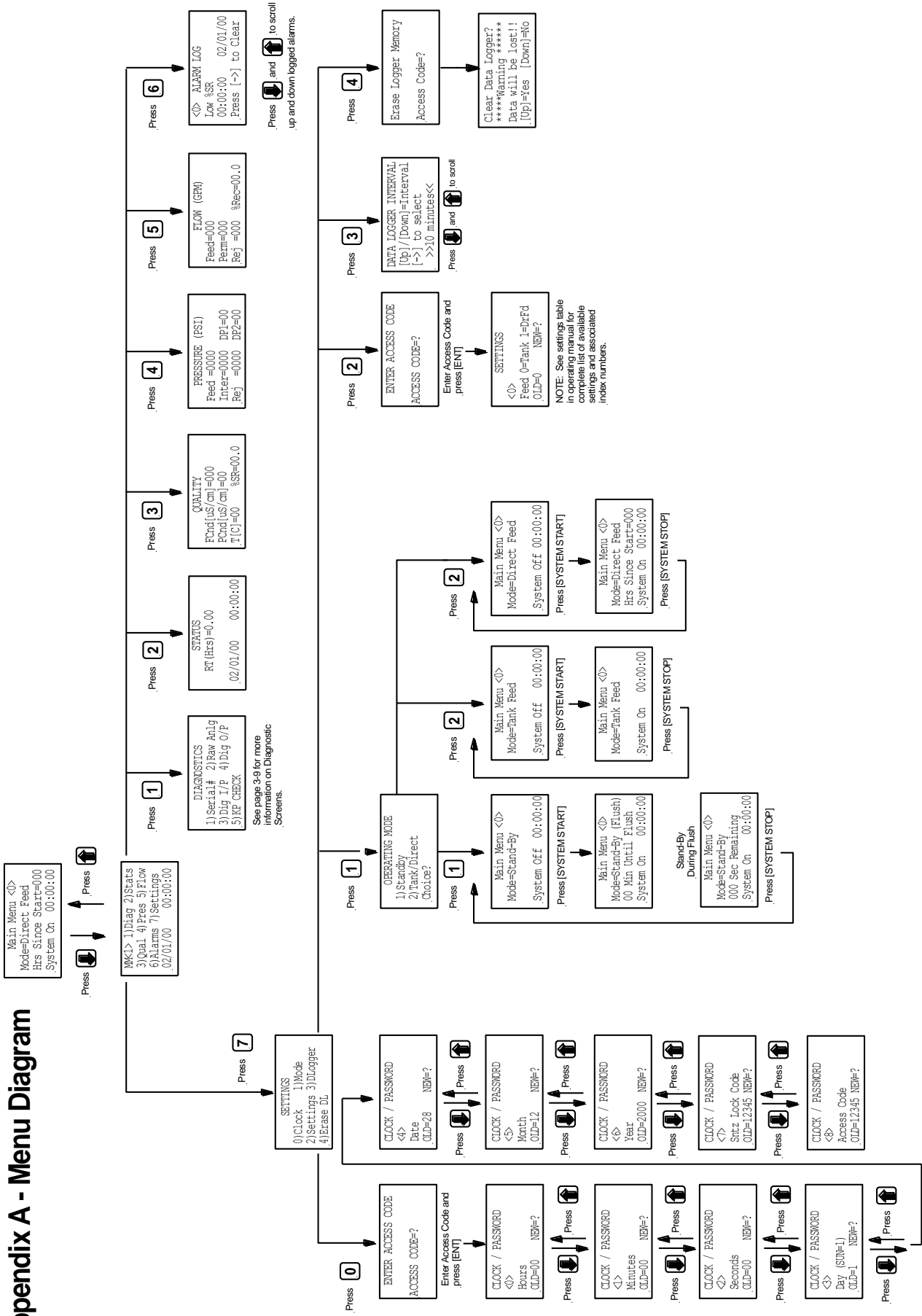

Appendix B - Technical Bulletins

Transient Surge Suppression

Since its introduction, a number of the AL250-V2 units have been damaged by transient voltages. Units damaged by transient voltages may exhibit the following symptoms: Unit will not power-up, discrete inputs show ON and then OFF with no switch contact change, conductivity and/or temperature values bounce significantly or do not change at all, keypad buttons do not work, and unit displays odd alarms or error codes.

A transient voltage can be defined as any change in voltage, such as a spike, which is unexpected, undesirable, and often destructive. Transient voltages are less than 8.3 milli-seconds in duration and can range from a few milli-volts to 18,000 volts in a normal working environment. More destructive transient voltages can be generated by electrostatic discharges, inductive switching, motor commutation, nuclear electro-magnetic pulses, and lightning. The latter two sources generate voltage spikes into the millions of volts.¹

Transient voltages are common through out the US, however they are more common in certain geographic areas and may be exacerbated by environmental aspects such as: multiple story buildings, building ground surface area larger than 38,000 ft.², and buildings located more than 2000 ft. from a utility substation. The AL250-V2 has built in power conditioning equipment; however it will not suppress all transients.

A transient surge protector is a device which is typically used to protect electronic equipment from damage or destruction caused by transient voltages and surge currents. These destructive transients most often attack equipment through power input lines, signal input and output lines, data lines, and any other wire coming into or going out of a chassis containing electronics.¹

Many companies sell transient surge protection devices. A list of some of these companies is shown below. The list is provided for informational purposes only. No specific testing has been performed on these products and the performance of these products is not guaranteed to be effective when used with the AL250-V2.

Surge Suppression Manufacturers

- Innovative Technology www.itvss.com
- EFI www.efinet.com
- APC www.apc.com
- Tripp-Lite www.tripplite.com
- Panamax www.panamax.com
- Transtector www.transtector.com
- Maxivolt www.maxivolt.com

The surge suppressor should be connected to the primary side of the AL250-V2 transformer as close to the AL250-V2 power terminal blocks as possible. The conductors between the surge suppressor and the AL250-V2 terminal blocks should be kept as short as possible.

¹ Axiomatic Technologies Corporation

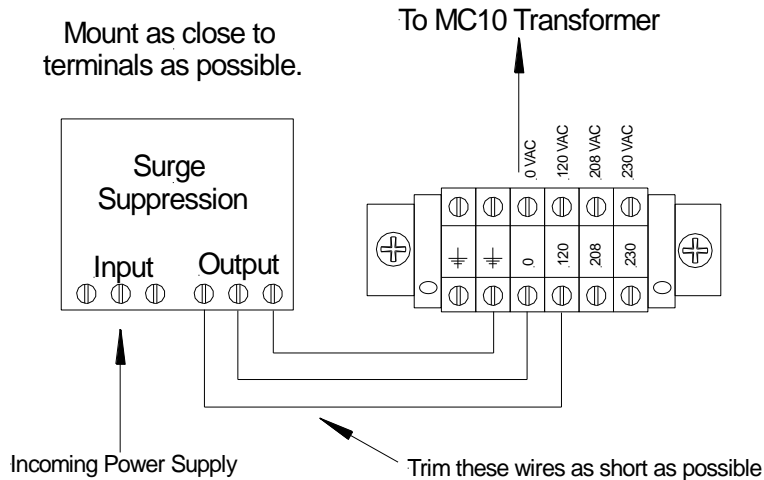

Discrete I/O Wiring

A quality transient surge suppressor limits the amplitude of transient over-voltages on the input power; however this does not eliminate the potential damage as a result of voltages that enter through the input and output wiring. The discrete inputs on the AL250-V2 monitor dry contact switches rated for 24VAC. The inputs are sinking inputs meaning that the current travels from the AL250-V2 through the switch contact and to the 24VAC neutral. **DO NOT APPLY VOLTAGE TO THE AL250-V2 INPUTS.**

The use of surge suppressors may prevent damage due to transient surges and extend the life of the AL250-V2. The use of a surge suppressor does not replace the need for a quality earth ground, a “clean” power supply, and good electrical wiring practices.